

SCREED CHAIR – ADJUSTABLE

Screed Chair – Adjustable, is available in 1" diameter x (2-1", 3-1", 5-1") heights for slabs from 4" up to 11-1" and a 3" diameter x 5-1" height for slabs from 9-1" up to 16".

LH-32 SCREED CHAIR

Screed Chair Size	Slab Thickness	
	Minimum	Maximum
½" x 2-½"	3-½"	4-½"
½" x 2-½"	4-½"	5-½"
½" x 3-½"	5-½"	7-½"
½" x 5-½"	7-½"	11-½"
¾" x 5-½"	9-½"	13-½"
¾" x 5-½"	13-½"	16-½"



LH-32

WARNING: Products shown above are not intended to support mechanical screeding machines. For manual screed operations only.

LH-34 SCREED CHAIR – FILL TYPE

The LH-34 Screed Chair – Fill Type, provides four legs for increased stability when used on compacted fill for slab on grade applications. Available in both 1" and 3" diameter with heights same as LH-32.

The LH-38 Screed Chair – Drive Type, is designed with heavier wire to permit use in more densely compacted sub bases. This chair also available in both ½" and ¾" diameter with heights same as the LH-32.

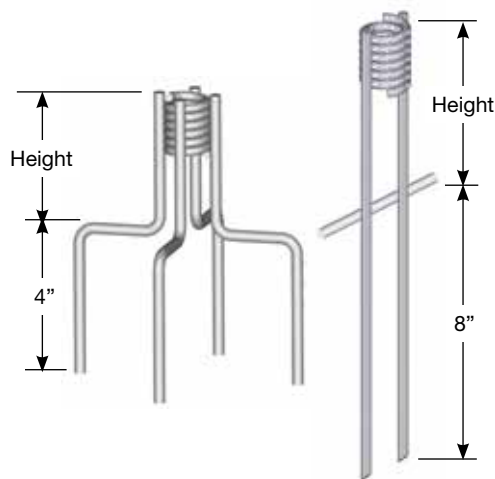

LH-40



LH-40 SCREED CHAIR – HEAVY DUTY

The LH-40 Screed Chair – Heavy Duty, is designed as a heavy rigid chair based for use with vibratory screed equipment. This chair is made with four heavy legs equally spaced with cross bracing to prevent leg spreading. The heavy duty base features a single 1" diameter free-fit ferrule (no threads). Available heights are shown in the table below.

To Order, Specify: quantity, type, diameter, height or length.